

MODEL A TOWN SEDAN

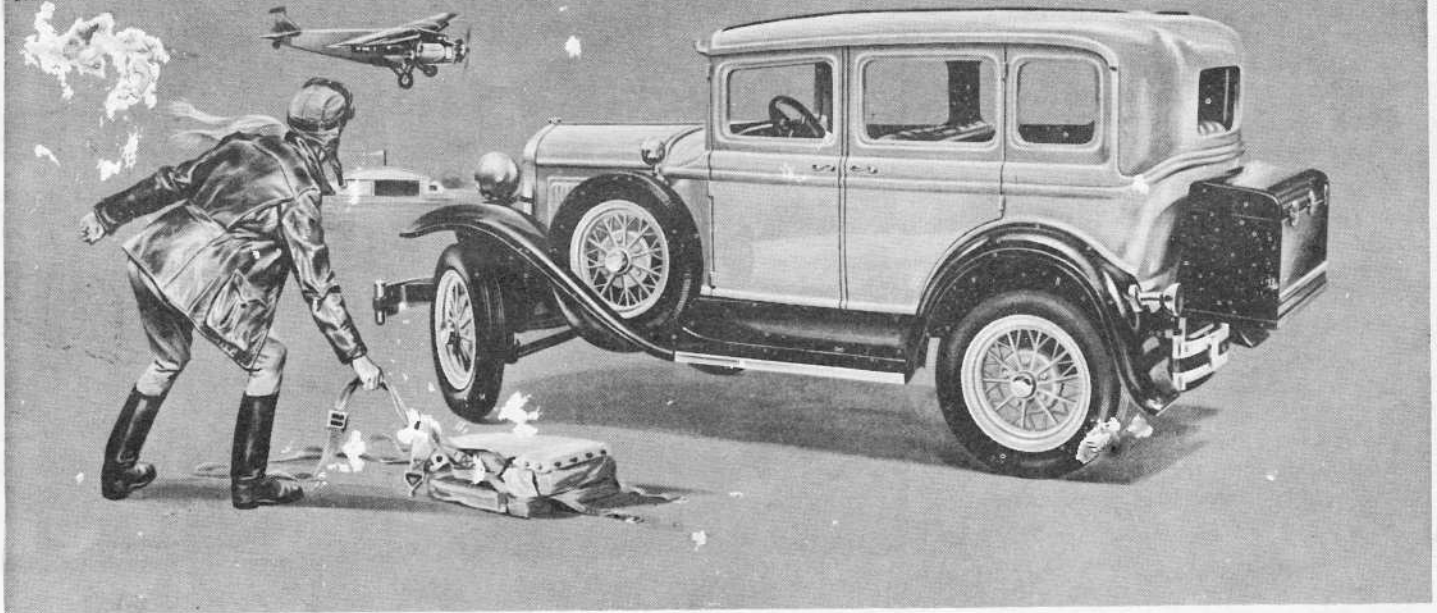

The venerable Model T reached the end of the line on March 26, 1927. Her seemingly imperishable lines had finally revealed her age. While sales were still astronomical, younger competitors were crowding her off the stage.

It was time for a change and Henry Ford knew it. By May 1927, the Model A was out of the planning stage and ready for production. On October 20, 1927, the first engine came down the line. On December 2, the Model A bowed to the public. The planetary transmission was replaced by a standard three-speed shift. The flywheel magneto gave way to coil and battery ignition. There were instruments on the instrument panel and lights to read them by. There was a foot accelerator and, for the first time, shock absorbers, four-wheel mechanical brakes, wire wheels, and a choice of colors.

Model A was, in short, a modern car that would bridge the gap between the T and later V-8. Almost 5,000,000 were sold and many like the T, are running yet.

Henry Ford's 20,000,000th car was a Model A Town Sedan which rolled off the River Rouge assembly line on April 14, 1931. Its serial number was A 4521600. The "Twenty Millionth Ford" was proudly lettered, not only on the sides, but even on the roof, attesting to Henry Ford's air-mindedness.

The design of the Town Sedan closely resembled the contemporary Lincoln car and was dubbed "The Baby Lincoln."

One Town Sedan owner made his trunk into a kitchenette which sported a table, refrigerator, pantry and stove. He had a locker on the running board, and even had a hinged front seat that made up into a bed.

A testimony to the popularity of the Model A is the existence of hundreds of Model A Clubs all over the country. Of the original 5,000,000 Model A Fords produced, there are 80,000 registered for daily use in the State of Pennsylvania alone. An estimated 929,000 are registered throughout the United States.

IMPORTANT! —BEFORE BEGINNING ASSEMBLY, READ AND UNDERSTAND YOUR INSTRUCTIONS. Use pliers to break ejection pins from castings. Clean flash from castings with file contained in kit or pen knife. Using screws provided, pre-tap all screw holes. This is done by turning the proper sized screws into the screw holes and then removing them again. (Screws will drive more easily if they are first rubbed on a bar of soap.)

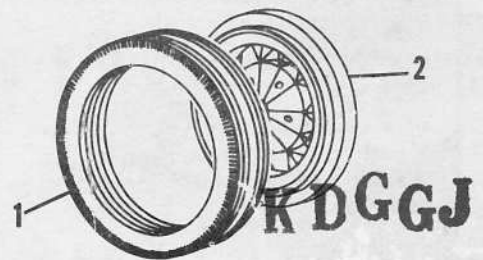
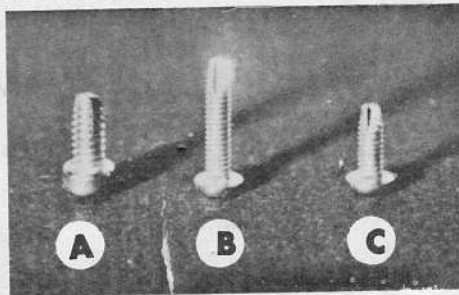
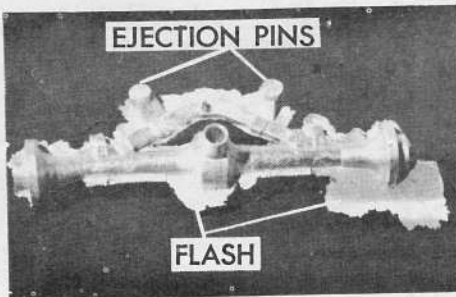

READ AND UNDERSTAND YOUR INSTRUCTIONS.

1. Slide tire (1) on to wheel (2)

- Attach two wheels to rear end assembly using screw (A), so that lug nuts face out. Insert drive shaft (3) into rear end assembly (3a).
- Attach wheel drums (4) (5) to front axle and spring assembly (6) using screw (B), so that boss on front axle faces forward. Assemble tie rod (7) to wheel drums using two screws (C). Fasten two wheels to front wheel drums with screws (A).

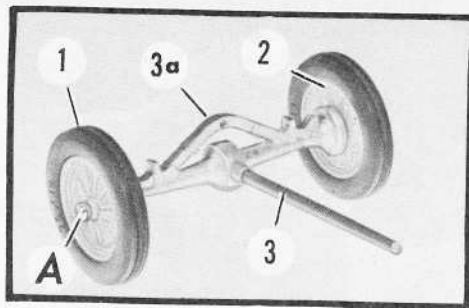

STEP No. 2

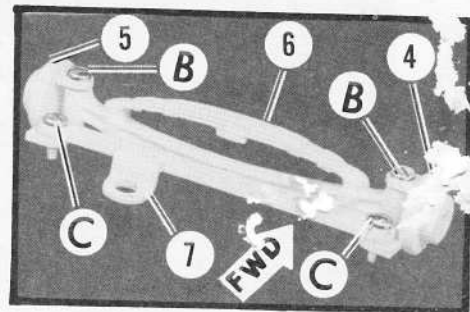

STEP No. 3

- Place gear shift (8) in slot provided on left side of engine block (9). Place right half of engine (10) on top. Insert engine head (11) in slot on top of block. Secure entire engine assembly with screw (C). Attach fan (12).
- Rest engine on engine support brackets. Insert drive shaft into rear of transmission. Spring of rear end assembly slides into spring housing and is secured to frame (13) with screw (C).

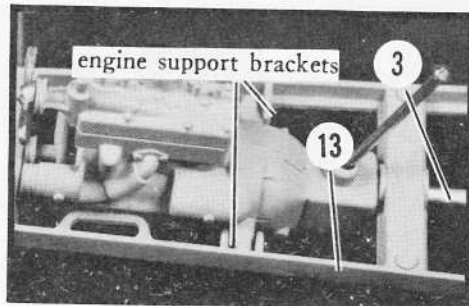

STEP No. 5

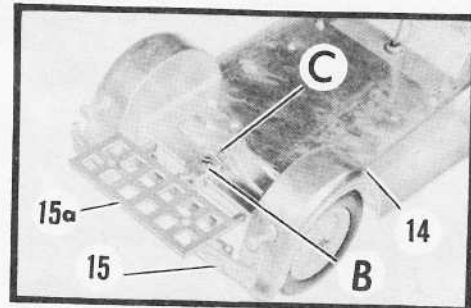

STEP Nos. 5 & 6

- Drop chassis (14) in position on top of frame. Insert rear bumper (15) into slots provided. Position luggage rack (15a) over bumpers. Use screw (B) to secure luggage rack, chassis and rear bumpers to frame. Insert front end assembly into front spring housing with tie rod toward rear of car. Place radiator (16) in front of front spring housing. Attach radiator and front end assembly to frame with screw (C). Attach hose (17) to radiator.

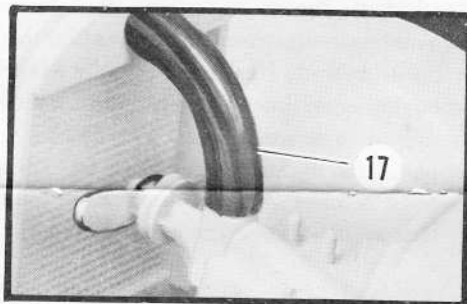

STEP No. 6

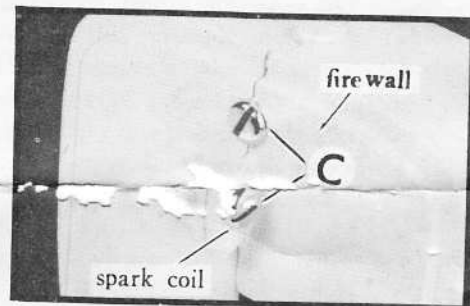

STEP No. 7

- Press two halves of body (18) (19) together and secure with screw (C) through spark coil. Press steering wheel (20) onto steering column (21). Insert steering column through dashboard (22) and tie rod. Attach dashboard to body with screw (C) through fire wall. Attach body to frame with two screws (B).

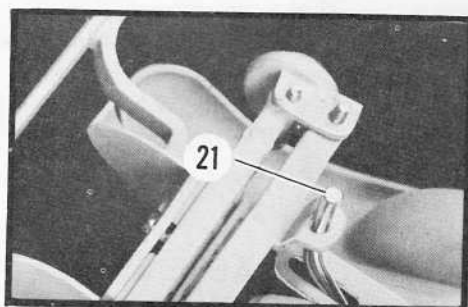

STEP No. 7

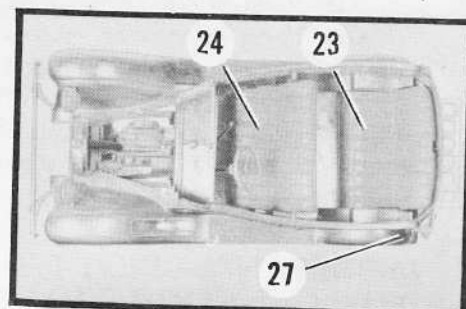

STEP Nos. 8 & 9

- Drop front and rear seats (23) (24) into position and fasten from underneath with screw (C). Slide two halves of hood (25) (26) together and place in position.
- Cement tail light (27) into rear of rear fenders.
- Press lenses (28) into headlight (29). Press headlight assembly into holes in front fenders.

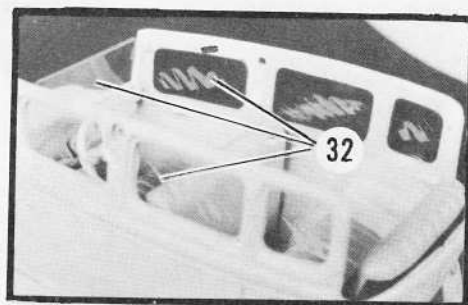

STEP No. 12

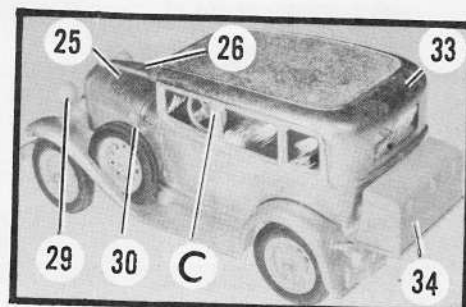

STEP Nos. 8, 10, 11 & 13

- Insert parking lights (30) (31) into upper cowl.
- Cut plastic windows (32) by following pattern provided on Page 4. Slide windows and windshield into appropriate slots.
- Position top of sedan (33) and secure to body with screw (C) in center of door post on each side. Place trunk (34) on luggage rack.

1. T
2. V
3. D
3a R
4. W
R
5. W
6. F
7. T
8. G
9. E
10. R
11. E
12. F
13. F
14. C
15. K
16. L
17. R
18. C

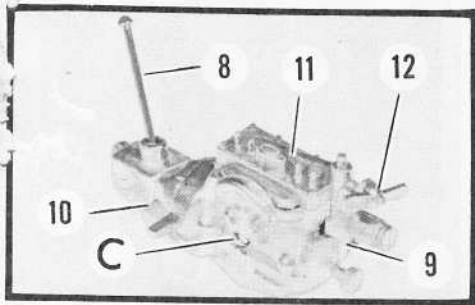

STEP No. 4

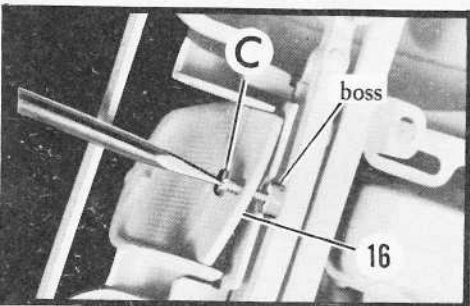

STEP No. 6

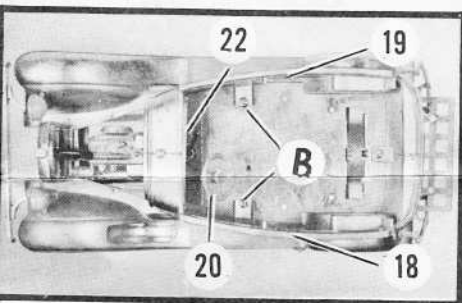

STEP No. 7

If any parts should be missing, circle missing parts on parts list, cut out coupon, print name and address on other side, and mail to:

THE HUBLEY MANUFACTURING COMPANY
SCALE MODEL DIVISION
P. O. BOX 1543, LANCASTER, PA.

857K Parts List

- | | |
|------------------------------|--------------------------|
| Tire 1 2 3 4 5 | 19. Body, Right |
| Wheel 1 2 3 4 5 | 20. Steering Wheel |
| Drive Shaft | 21. Steering Column |
| Rear End | 22. Dashboard |
| Wheel Drum, Right | 23. Rear Seat |
| Wheel Drum, Left | 24. Front Seat |
| Front Axle & Spring Assembly | 25. Hood, Left |
| Tie Rod | 26. Hood, Right |
| Gear Shift Lever | 27. Tail Light 1 2 |
| Engine Block, Left | 28. Headlight Lens 1 2 |
| Engine Block, Right | 29. Headlight Assembly |
| Engine Head | 30. Parking Light, Left |
| Fan | 31. Parking Light, Right |
| Frame Chassis | 32. Plastic For Windows |
| Rear Bumper | 33. Top |
| Luggage Rack | 34. Trunk |
| Radiator | 35. Screws A, B, C |
| Radiator Hose | 36. Decal |
| Body, Left | 37. File |

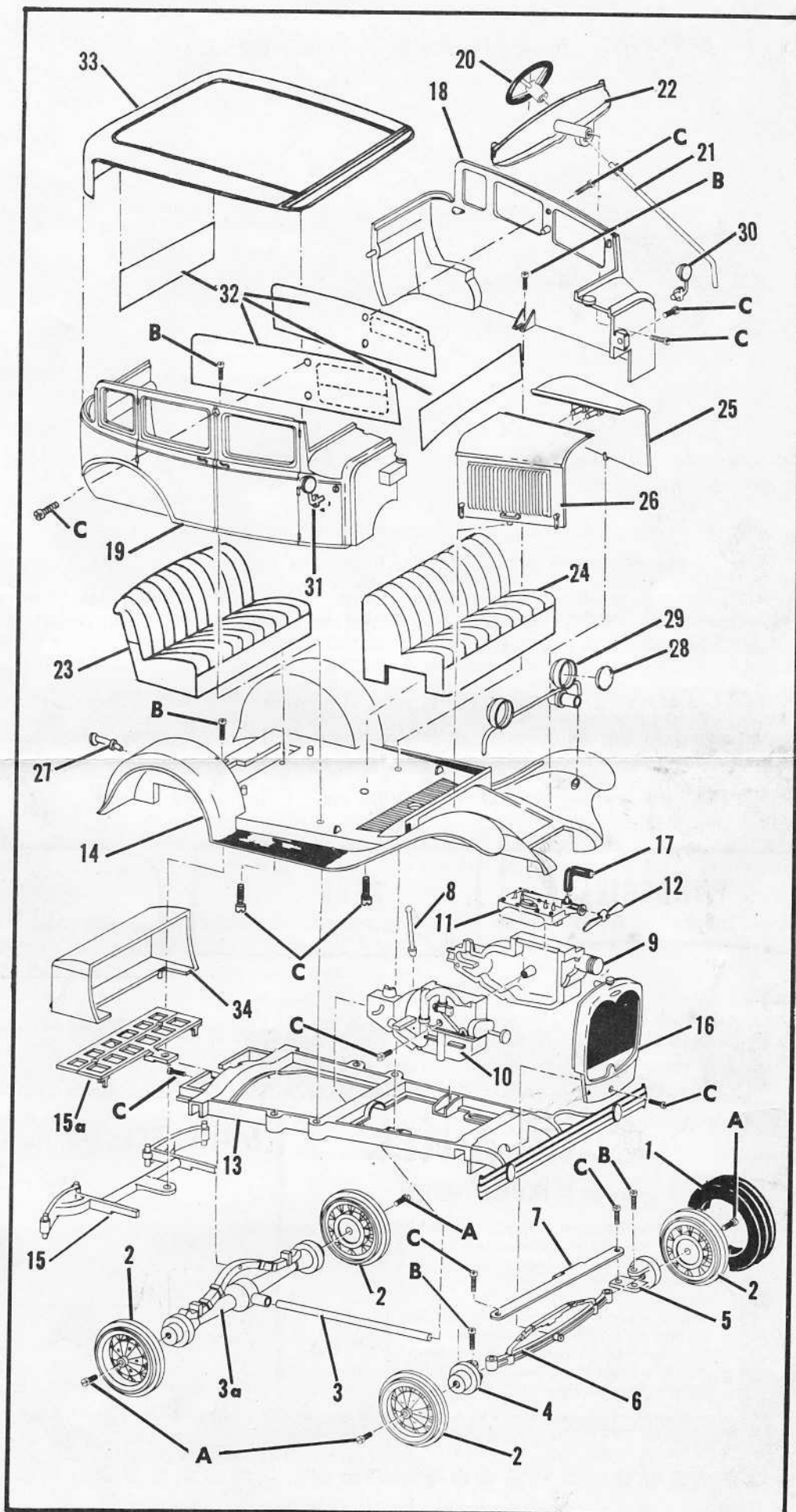

MODEL A kits by Hubley®



In order to achieve an outstanding and authentic finish on your Hubley Metal Kit, the following steps are suggested:

1. All parts should be thoroughly cleaned and any loose metal dust removed.
2. Rub lightly with fine steel wool or Flex-i-grit reusable sandpaper, (available at your Hobby store), until smooth.
3. Apply two or three coats of lacquer or enamel in the color desired, rubbing lightly between coats with fine steel wool. Enamel is recommended for hand brushing, but both lacquer and enamel are available in pressure spray cans at your hobby dealer. Wood part of body should be light tan.
4. **CAUTION**—Do not paint plastic parts with lacquer. This will cause wrinkling or crazing of the smooth surface.
5. To achieve a shiny finish on the chrome parts, any of the following methods may be used:
 - a. Buff parts with buffing wheel and then nickel or chrome plate.
 - b. Paint with aluminum enamel.
 - c. Polish with jewelers' rouge, buff, and then apply a coat of clear lacquer.



Guarantee by Hubley®

The component parts of the **Model A** have been manufactured under rigidly controlled conditions and carefully inspected for faulty material and workmanship.

Hubley assumes no responsibility for lost or spoiled parts as the result of faulty assembly or negligence. Your hobby dealer cannot supply replacement parts for this kit. Address all inquiries and requests to The Hubley Manufacturing Company.

MAIL TO: THE HUBLEY MANUFACTURING CO.
SCALE MODEL DIVISION
Drawer 240, Lancaster, Pa.

(Print Plainly)

NAME _____ AGE _____

ADDRESS _____

CITY & STATE _____